

PARTS LIST			
ITEM	QTY	PART NUMBER	DESCRIPTION
1	8	M3x8mm Pan Screw	Front/Rear Panel Screws
2	8	M4x16mm CSK Screw	Bezel Screws
3	8	M3x6mm CSK Screw	Base Panel Screws
4	8	M6420000	Clips for Trims
9	1	M6403485	Rear Panel
10	2	M6401085	Bezel
11	2	M6400057	Front Trim
12	2	M6400077	Rear Trim
15	1	M6403035	LH Chassis Plate
16	1	M6402033	Wrap Around Cover
17	1	M6403036	RH Chassis Plate
16	1	M6403122	Base Panel
18	2	M6420204	Tilted Technofeet Kit

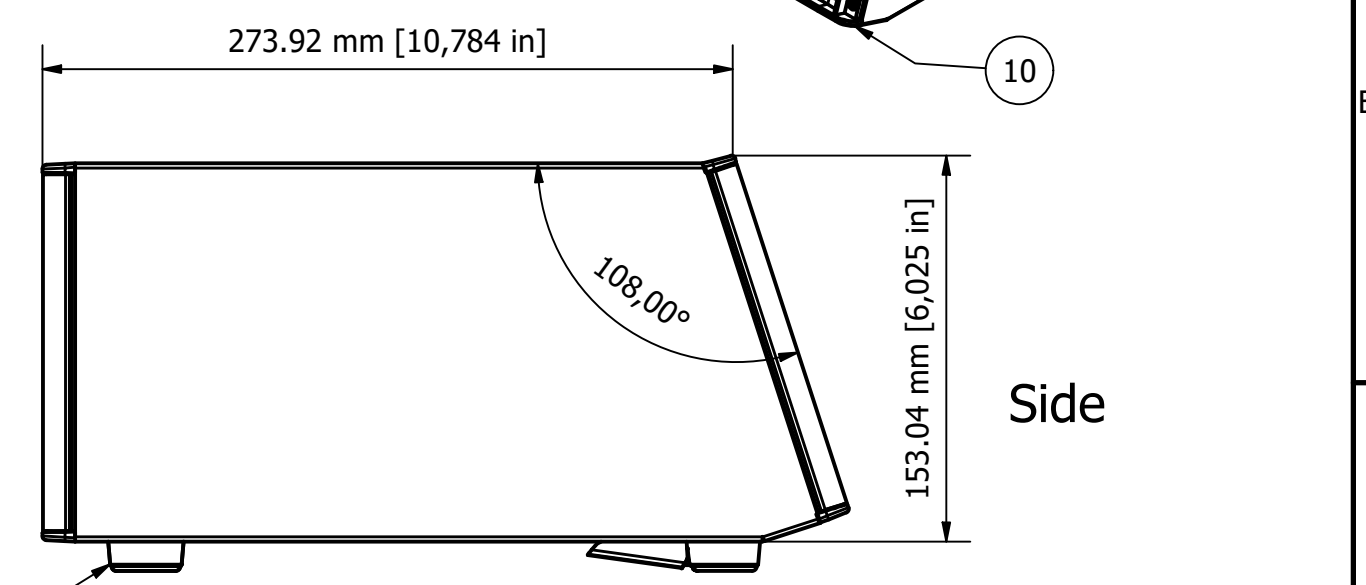
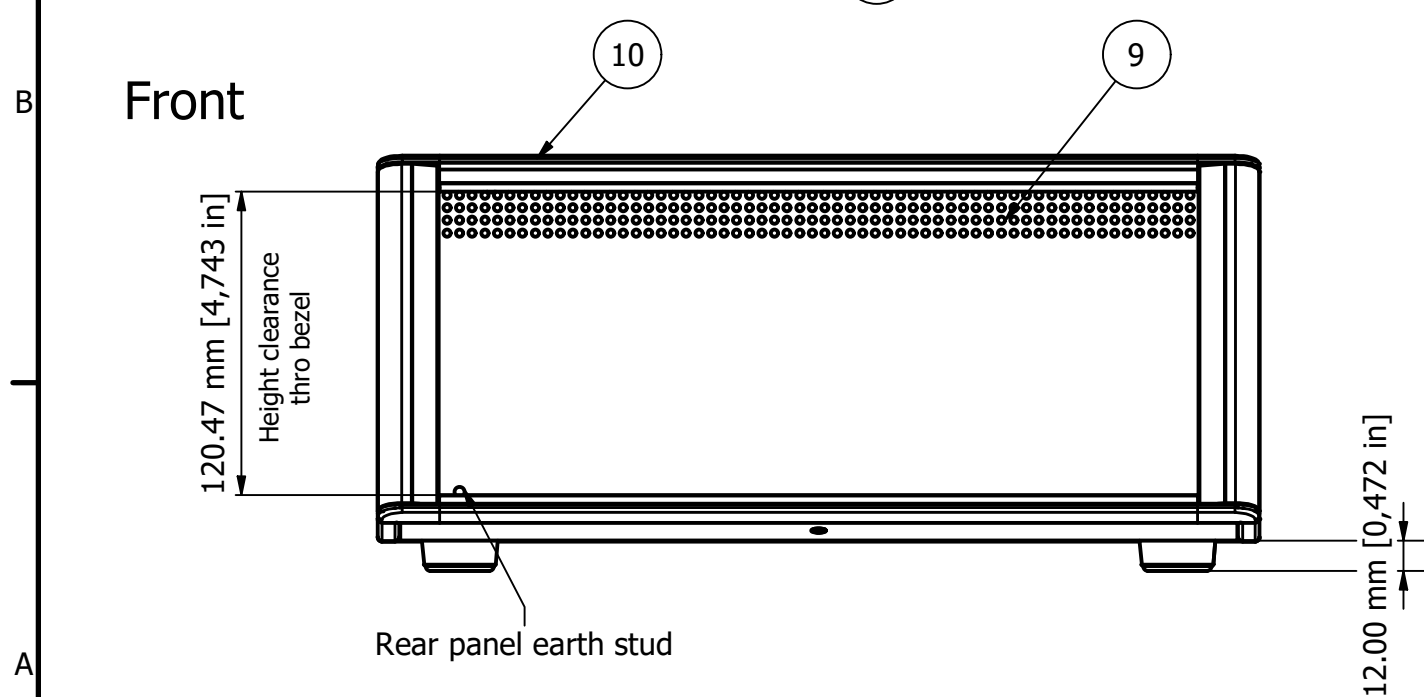
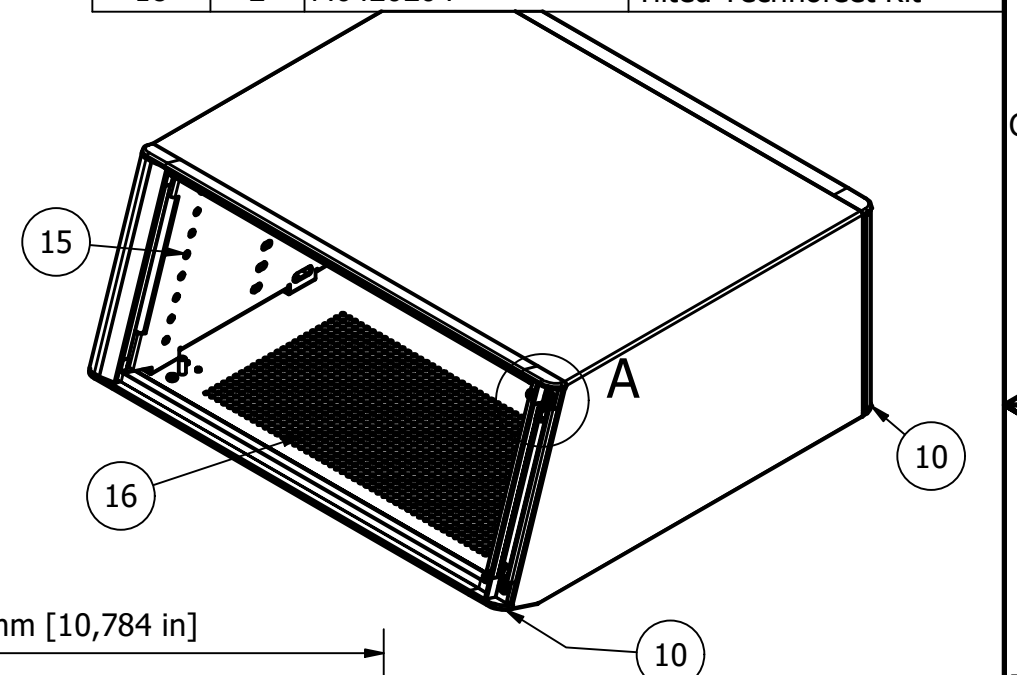

Front panel (M6400707) sold seperately

FIRST ANGLE PROJECTION

Designed by L Clark	Description Technomet SL315 - Anthracite RAL 7016	Date 29/04/2024	Scale 1:3
METCASE ENCLOSURES 15 Brunel Way, Segensworth East, Fareham, Hampshire, PO15 5TX, UK. Tel: +44 (0)1489 583858 Email: sales@metcase.co.uk		METcase™ www.metcase.com Part Number M6436354	
		Issue 1	Sheet 1 / 2

© OKW Enclosures Ltd (Date as shown). This drawing contains proprietary information of OKW Enclosures Ltd and is tendered subject to the following conditions. The information be retained in confidence, not be reproduced or copied, and not be used or incorporated in any product, unless permission is obtained in writing from OKW Enclosures Ltd.

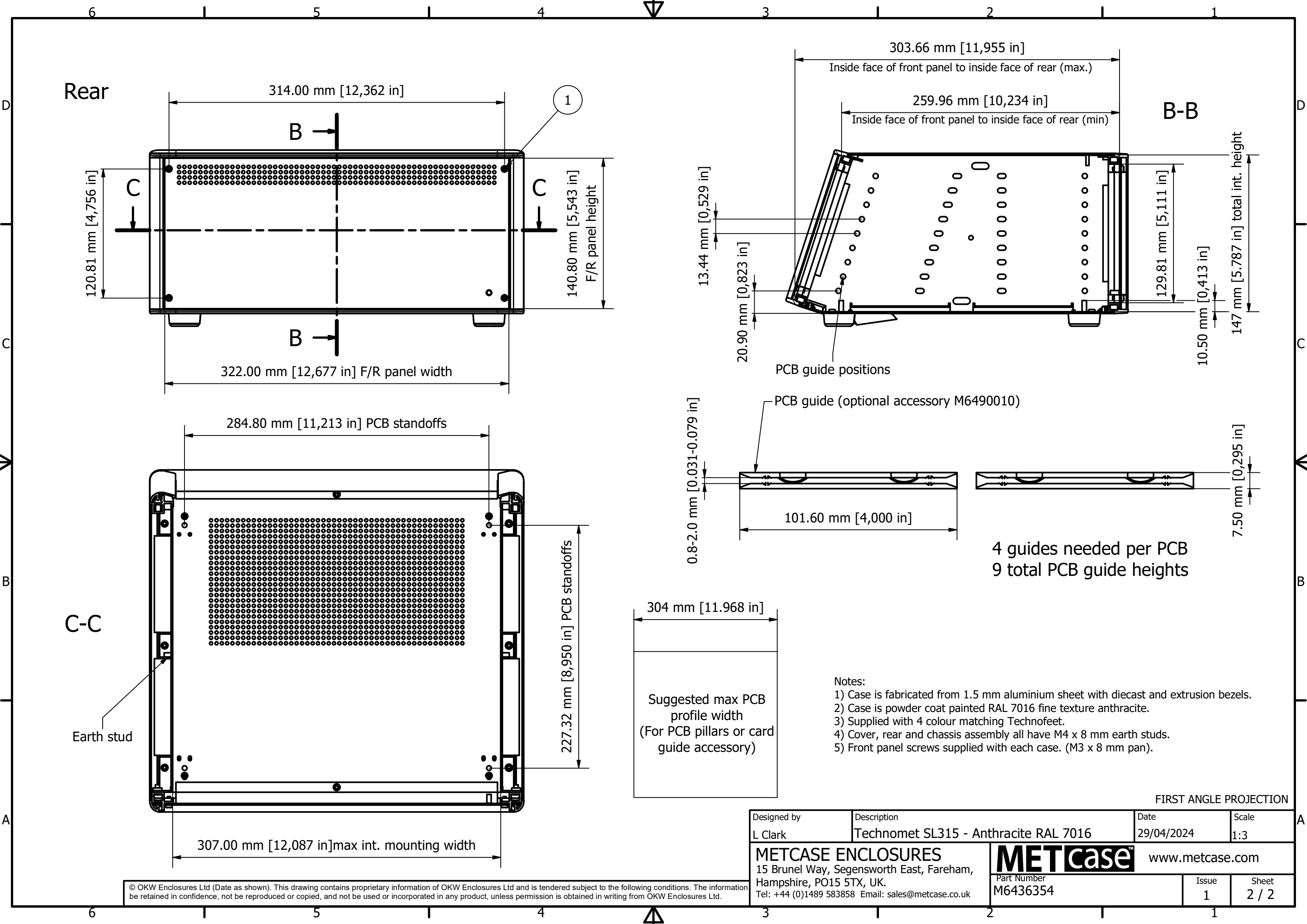

Rear

314.00 mm [12,362 in]

120.81 mm [4,756 in]

140.80 mm [5,543 in]
F/R panel height

322.00 mm [12,677 in] F/R panel width

284.80 mm [11,213 in] PCB standoffs

227.32 mm [8,950 in] PCB standoffs

307.00 mm [12,087 in] max int. mounting width

Earth stud

303.66 mm [11,955 in]

Inside face of front panel to inside face of rear (max.)

259.96 mm [10,234 in]

Inside face of front panel to inside face of rear (min)

13.44 mm [0,529 in]

20.90 mm [0,823 in]

B-B

129.81 mm [5,111 in]

10.50 mm [0,413 in]

147 mm [5,787 in] total int. height

PCB guide positions

PCB guide (optional accessory M6490010)

0.8-2.0 mm [0.031-0.079 in]

101.60 mm [4,000 in]

7.50 mm [0,295 in]

4 guides needed per PCB
9 total PCB guide heights

304 mm [11.968 in]
Suggested max PCB profile width
(For PCB pillars or card guide accessory)

Notes:

- 1) Case is fabricated from 1.5 mm aluminium sheet with diecast and extrusion bezels.
- 2) Case is powder coat painted RAL 7016 fine texture anthracite.
- 3) Supplied with 4 colour matching Technofeet.
- 4) Cover, rear and chassis assembly all have M4 x 8 mm earth studs.
- 5) Front panel screws supplied with each case. (M3 x 8 mm pan).

FIRST ANGLE PROJECTION

Designed by L Clark	Description Technomet SL315 - Anthracite RAL 7016	Date 29/04/2024	Scale 1:3
METCASE ENCLOSURES 15 Brunel Way, Segensworth East, Fareham, Hampshire, PO15 5TX, UK. Tel: +44 (0)1489 583858 Email: sales@metcase.co.uk		METcase™ www.metcase.com Part Number M6436354	
		Issue 1	Sheet 2 / 2

© OKW Enclosures Ltd (Date as shown). This drawing contains proprietary information of OKW Enclosures Ltd and is tendered subject to the following conditions. The information be retained in confidence, not be reproduced or copied, and not be used or incorporated in any product, unless permission is obtained in writing from OKW Enclosures Ltd.